



## DOSIC®

THE COMPACT STAINLESS-STEEL SENSOR FOR FLEXIBLE FLOW MEASUREMENT

Flow sensors

**SICK**  
Sensor Intelligence.

# PRECISE MEASUREMENTS IN CHALLENGING ENVIRONMENTS

## DOSIC® - the compact stainless-steel flow sensor

The non-contact DOSIC® ultrasonic flow sensor is used to detect the flow volume of conductive and non-conductive liquids and can measure liquids in a variety of different industries, as well as in high-stress and hygienic environments. Thanks to its space-saving, compact size, the DOSIC® can be perfectly integrated into any machine environment.





**TECHNOLOGY FOR GREATER FLEXIBILITY AND EFFICIENCY**

It's so much easier to go with the flow. The DOSIC® harnesses this principle, using an ultrasonic beam to measure the transit time of a liquid in the direction of flow.

Two configurable digital inputs/outputs and analog outputs and an IO-Link interface to a superordinate control unit ensure that you get just the right start position. Furthermore, no special calibration process is required prior to taking a measurement.

The seal-free, self-draining measuring tube also significantly enhances the reliability of the measuring process.

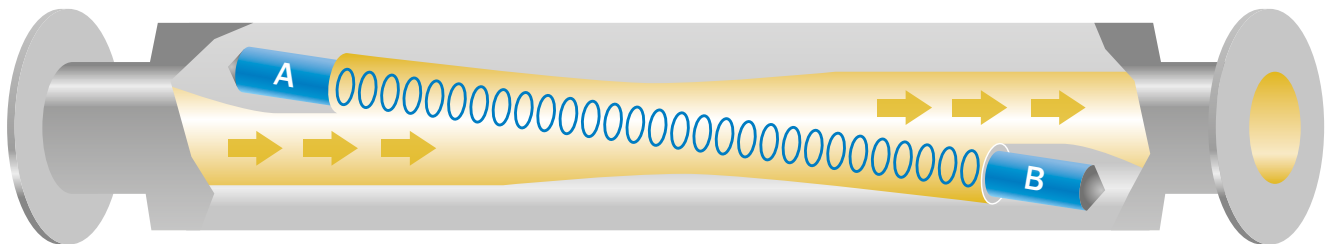

The DOSIC® uses ultrasonic technology to measure the flow of variable liquids in their direction of flow.

# SO MANY APPLICATIONS, SO MANY BENEFITS: A SUMMARY

The new DOSIC® ultrasonic flowmeter from SICK offers a flexible, efficient, cost-effective option for measuring flow. In addition to having a hygienic, compact, robust design, the sensor is also easy to install and operate.



## Hygienic design

- Meets the highest standards of hygiene: EHEDG-certified and FDA-compliant
- The straight measuring tube prevents deposits from forming
- The lack of moving components in the sensor ensures process reliability
- The IP67 and IP69 enclosure rating means that a high-pressure cleaner can be used to clean the sensor
- High product service life thanks to high-quality stainless steel
- CIP and SIP-resistant

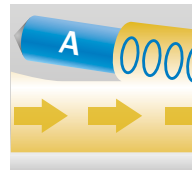

## Ultrasonic technology

- Measures non-conductive liquids precisely
- Non-contact measurement, i.e. there is no contact between the sensor and the flow media
- Alternative to a Coriolis mass flow meter

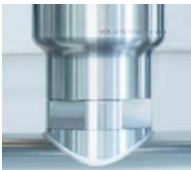

## A robust, compact design

- Suitable for demanding production environments and aggressive liquids
- High-quality stainless-steel housing for extreme durability
- The seal-free measuring tube reduces maintenance effort
- Compact design means the sensor can be integrated into the most confined of spaces



## Plug-in and measure

- Initial medium calibration replaced by automatic sensor calibration
- The IO-Link 1.1 interface communicates with the machine environment (Industry 4.0)
- The integrated display makes the flow sensor easier to operate

## Flow measurement for the food industry

### Task:

- Monitoring the flow of drinking chocolate, beer, olive oil, demineralized water etc.

### Special features of the product in this application:

- Detects conductive and non-conductive liquids
- EHEDG-certified and FDA-compliant



## Use in CIP/SIP systems

### Task:

- Monitoring the flow of cleaning agents

### Special features of the product in this application:

- CIP and SIP-resistant
- High measurement accuracy
- Non-corrosive stainless steel



## Flow measurement in cooling circuits

### Task:

- Monitoring the flow of cooling water

### Special features of the product in this application:

- High measurement accuracy
- Easy to commission



# THE COMPACT STAINLESS-STEEL SENSOR FOR FLEXIBLE FLOW MEASUREMENT

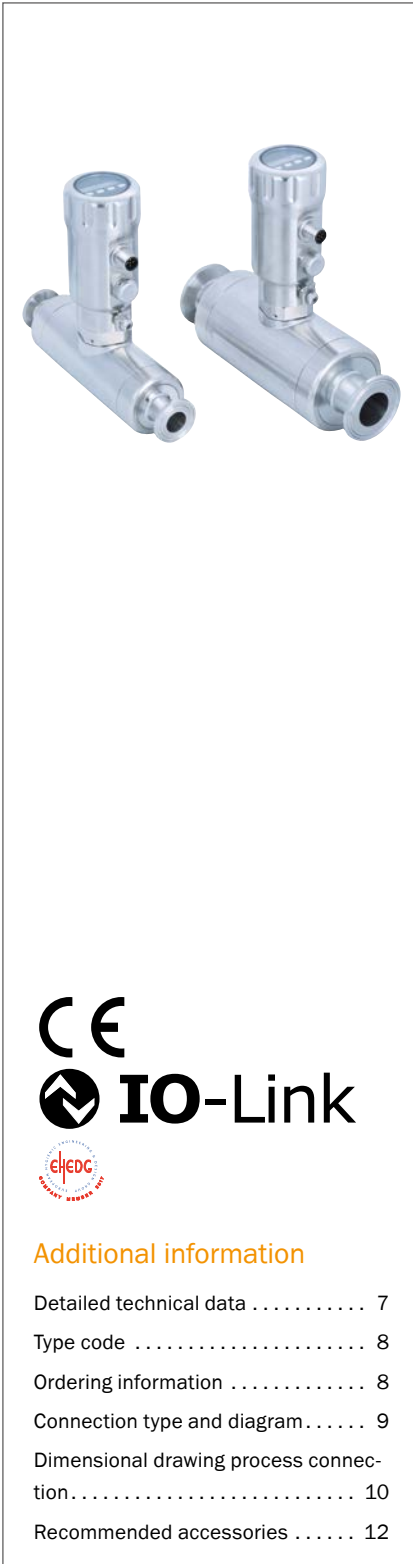

## Product description

The non-contact DOSIC® flowmeter detects the flow volume of conductive and non-conductive liquids based on ultrasonic technology. With its measurement channel and stainless-steel housing, the ultrasonic flowmeter is suitable for measuring tasks in hygienic environments. The compact and rugged design offers a wide variety of application possibilities, including in those where space restric-

tions or aggressive media play a role. Installation is quick and easy, and does not require medium calibration. The seal-free, self-draining measuring tube enhances process reliability. Up to two configurable digital and analog outputs as well as the IO-Link interface ensure the right initial situation. The DOSIC® is EHEDG-certified and FDA-compliant.

## At a glance

- Flow measurement for water and oil-based liquids
- Seal-free stainless-steel 316L sensor with Ra ≤ 0.8
- Straight, self-draining measuring tube
- Compact design with short installation lengths
- Configurable digital outputs
- Temperature measurement
- IP67/69 enclosure rating, CIP/SIP-compatible, IO-Link version 1.1

## Your benefits

- Flexible measurement system for all industries and liquids
- Versatile use for conductive and non-conductive liquids and temperature measurement
- Short installation lengths and a compact design enable installation in applications with limited space
- Food-safe thanks to rust-free stainless steel and hygienic design
- Quick installation without medium calibration
- User-friendly application thanks to rotatable housing and display
- Straight measuring tube reduces pressure loss, thus reducing energy costs

→ [www.sick.com/DOSIC](http://www.sick.com/DOSIC)

For more information, simply enter the link or scan the QR code and get direct access to technical data, CAD design models, operating instructions, software, application examples, and much more.



## Detailed technical data

## Features

	DN 15	DN 25
Measurement	Ultrasonic	
Medium	Conductive and non-conductive liquids	
Nominal width measuring tube	DN 15	DN 25
Process temperature	0 °C ... +95 °C, up to 143 °C for 60 minutes	
Process pressure	-0.5 bar ... +16 bar	
Communication interface	IO-Link	
EHEDG approval	✓	
RoHS certificate	✓	
FDA	✓	

## Performance

	DN 15	DN 25
Minimum flow	≤ 0.5 l/min	≤ 1.5 l/min
Maximum flow	≤ 80 l/min	≤ 250 l/min
Inlet zone	5 x DN (7.5 cm)	5 x DN (12.5 cm)
Output zone	3 x DN (4.5 cm)	3 x DN (7.5 cm)
Conductivity	No limitation	
Accuracy of sensor element	± 1 % (From measured value) <sup>1)</sup>	
Reproducibility	0.5 %	
Response time	< 200 ms	

<sup>1)</sup> Under the following reference conditions: water 26 °C ± 2 K, 2.5 bar ± 0.5 bar, standard settings, DN15: 8 l/min ... 80 l/min, DN25: 25 l/min ... 250 l/min.

## Mechanics

	DN 15	DN 25
Process connection	Clamp (DIN 32676) DN 15 G ¾ DIN 11851 DN 15 ¾" NPT (depending on type)	Clamp (DIN 32676) DN 25 G 1 ¼ DIN 11851 DN 25 1 ¼" NPT (depending on type)
Wetted parts	Stainless steel 1.4404 (Ra ≤ 0,8 µm)	
Housing material	Stainless steel 1.4305	
Housing design	With viewing window made from PMMA (acrylic glass)	
Enclosure rating	IP67/IP69 (DIN EN 60529)	
Weight	Approx. 2 kg	Approx. 3 kg

## Electronics

Supply voltage	12 V DC ... 30 V DC <sup>1)</sup>
Power consumption	< 3 W without output load
Initialization time	≤ 5 s
Protection class	III
Electrical connection	Round connector M12 x 1, 5-pin / Round connector M12 x 1, 8-pin (depending on type)

<sup>1)</sup> All connections are reverse polarity protected. Q<sub>A</sub> and Q<sub>B</sub> are short-circuit protected. Q1 and Q2 are short-circuit protected.

<sup>2)</sup> Digital output configuration: PNP/NPN/push-pull/open collector.

<sup>3)</sup> Selectable analog output: Flow/Temperature.

<sup>4)</sup> There are 100 mA for each output PNP and NPN available.

<b>Output signal</b>	1 x analog output: 4 mA ... 20 mA, 2 x digital input or output (configurable) <sup>2) 3)</sup> 2 x analog output: 4 mA ... 20 mA, 2 x digital input or output (configurable) <sup>2) 3)</sup> (depending on type)
<b>Output current</b>	< 100 mA <sup>4)</sup>
<b>Output load</b>	4 mA ... 20 mA, 500 ohms when $U_v > 15\text{ V}$ , 350 ohms when $U_v > 12\text{ V}$
<b>Lower signal level</b>	3.5 mA ... 3.8 mA
<b>Upper signal level</b>	21.5 mA ... 20.5 mA
<b>Digital output</b>	≤ 100 mA
<b>Impuls/frequency output</b>	0 kHz ... 10 kHz
<b>Signal voltage HIGH</b>	> ( $U_v - 4\text{ V}$ )
<b>Signal voltage LOW</b>	< 3 V
<b>Inductive load</b>	< 1 H
<b>Capacitive load</b>	< 100 nF < 2.5 nF, IO-Link
<b>EMC</b>	EN 61326-2-3
<b>Limit digital inputs</b>	HIGH state voltage > 16.0 V LOW state voltage < 4.0 V
<b>MTTF</b>	> 63 years

<sup>1)</sup> All connections are reverse polarity protected.  $Q_A$  and  $Q_B$  are short-circuit protected.  $Q_1$  and  $Q_2$  are short-circuit protected.

<sup>2)</sup> Digital output configuration: PNP/NPN/push-pull/open collector.

<sup>3)</sup> Selectable analog output: Flow/Temperature.

<sup>4)</sup> There are 100 mA for each output PNP and NPN available.

### Ambient data

<b>Ambient operating temperature</b>	0 °C ... +60 °C
<b>Ambient storage temperature</b>	-40 °C ... +80 °C

### Type code

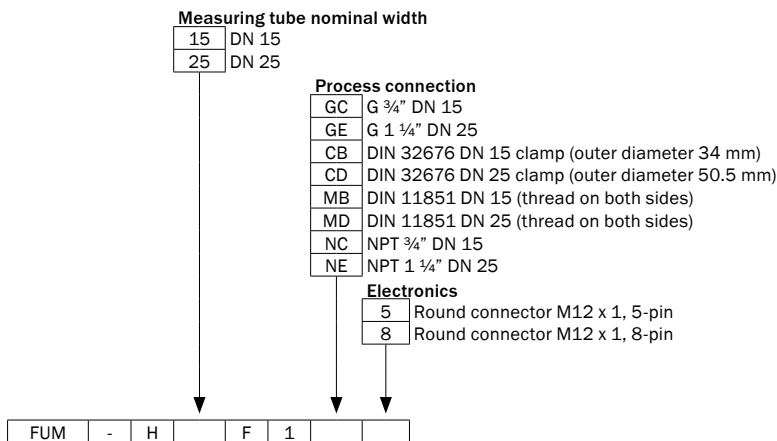

Not all variants of the type code can be combined!

### Ordering information

- **Nominal width measuring tube:** DN 15
- **Maximum flow:** ≤ 80 l/min

Process connection	Electrical connection	Type	Part no.
Clamp (DIN 32676) DN 15	Round connector M12 x 1, 5-pin	FUM-H015F1CB5	1072035
G 3/4"	Round connector M12 x 1, 5-pin	FUM-H015F1GC5	1082021



Process connection	Electrical connection	Type	Part no.
DIN 11851 DN 15	Round connector M12 x 1, 5-pin	FUM-H015F1MB5	1082020
3/4" NPT	Round connector M12 x 1, 5-pin	FUM-H015F1NC5	1082022
Clamp (DIN 32676) DN 15	Round connector M12 x 1, 8-pin	FUM-H015F1CB8	1082023
G 3/4	Round connector M12 x 1, 8-pin	FUM-H015F1GC8	1082024
DIN 11851 DN 15	Round connector M12 x 1, 8-pin	FUM-H015F1MB8	1082025
3/4" NPT	Round connector M12 x 1, 8-pin	FUM-H015F1NC8	1082026

- **Nominal width measuring tube:** DN 25
- **Maximum flow:** ≤ 250 l/min

Process connection	Electrical connection	Type	Part no.
Clamp (DIN 32676) DN 25	Round connector M12 x 1, 5-pin	FUM-H025F1CD5	1082027
G 1 1/4	Round connector M12 x 1, 5-pin	FUM-H025F1GE5	1082028
DIN 11851 DN 25	Round connector M12 x 1, 5-pin	FUM-H025F1MD5	1082029
1 1/4" NPT	Round connector M12 x 1, 5-pin	FUM-H025F1NE5	1082030
Clamp (DIN 32676) DN 25	Round connector M12 x 1, 8-pin	FUM-H025F1CD8	1082031
G 1 1/4	Round connector M12 x 1, 8-pin	FUM-H025F1GE8	1082033
DIN 11851 DN 25	Round connector M12 x 1, 8-pin	FUM-H025F1MD8	1082034
1 1/4" NPT	Round connector M12 x 1, 8-pin	FUM-H025F1NE8	1082035

### Connection type and diagram

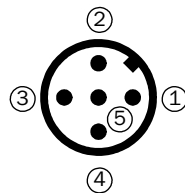
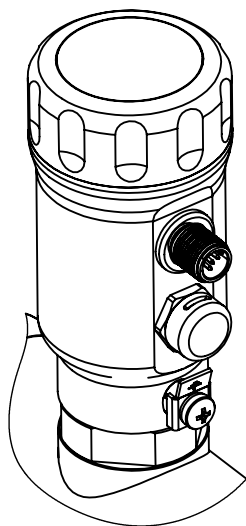

- ① L<sup>+</sup>: Supply voltage
- ② Q<sub>A</sub>: Analog current-voltage output
- ③ M: Ground, reference ground for current-voltage output
- ④ C/Q1: Switching output/input 1, PNP/NPN/push-pull/open collector/IO-Link communication
- ⑤ Q<sub>2</sub>: Switching output/input 2, PNP/NPN/push-pull/open collector/frequency/pulse output

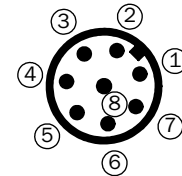
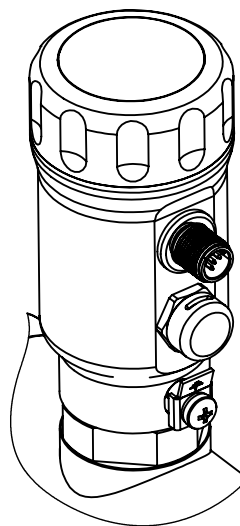

- ① L<sup>+</sup>: Supply voltage
- ② Q<sub>2</sub>: Switching output/input 2, PNP/NPN/push-pull/open collector/frequency/pulse output
- ③ M: Ground, reference ground for current-voltage output
- ④ C/Q1: Switching output/input 1, PNP/NPN/push-pull/open collector/IO-Link communication
- ⑤ No function
- ⑥ No function
- ⑦ Q<sub>A</sub>: Analog current output 4 mA ... 20 mA
- ⑧ Q<sub>B</sub>: Analog current output 4 mA ... 20 mA

Dimensional drawing process connection

DIN 11851 DN 15

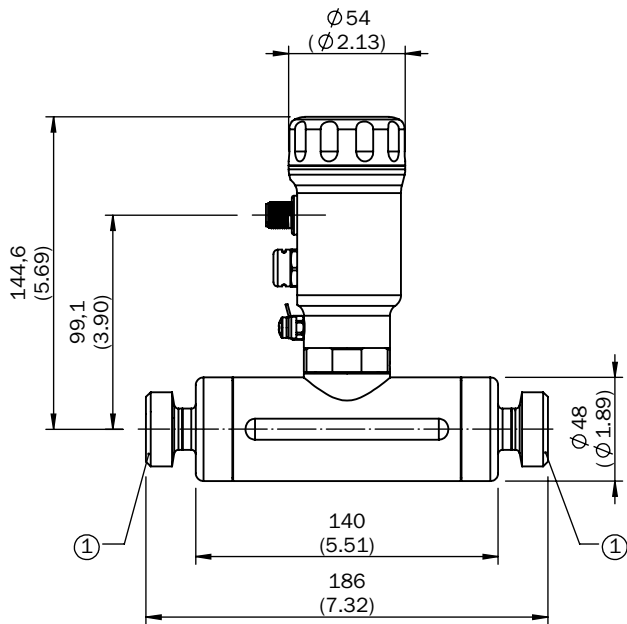

DN 15, G 3/4

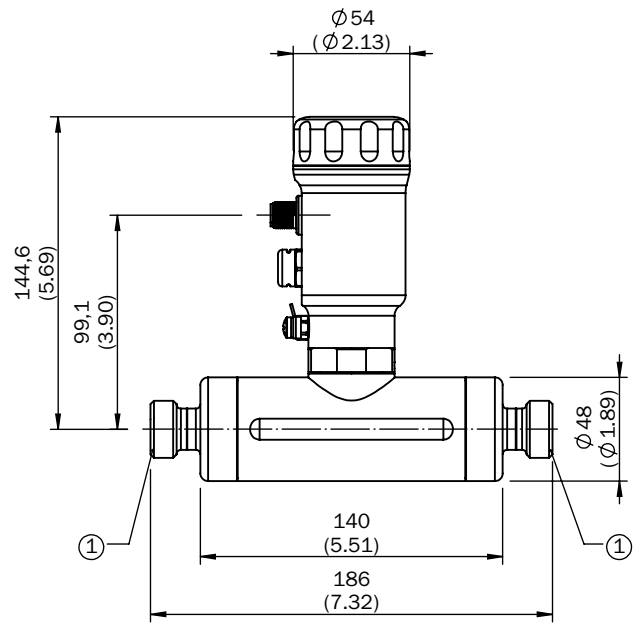

DN 15, 3/4" NPT

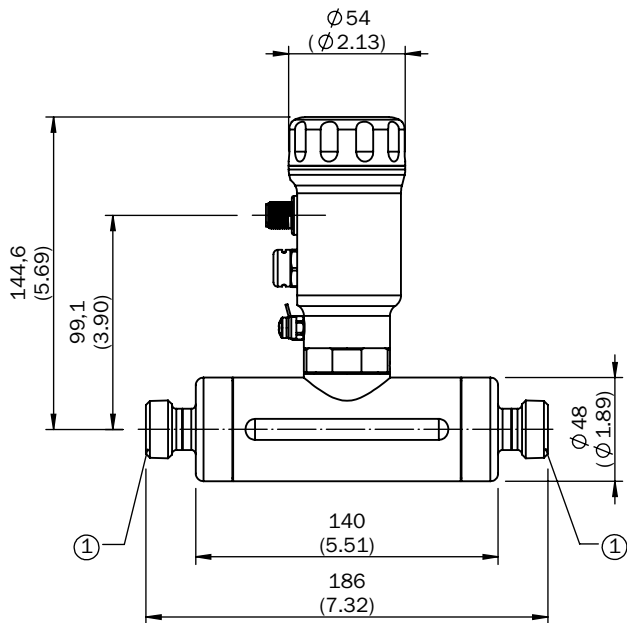

Clamp (DIN 32676) DN 15

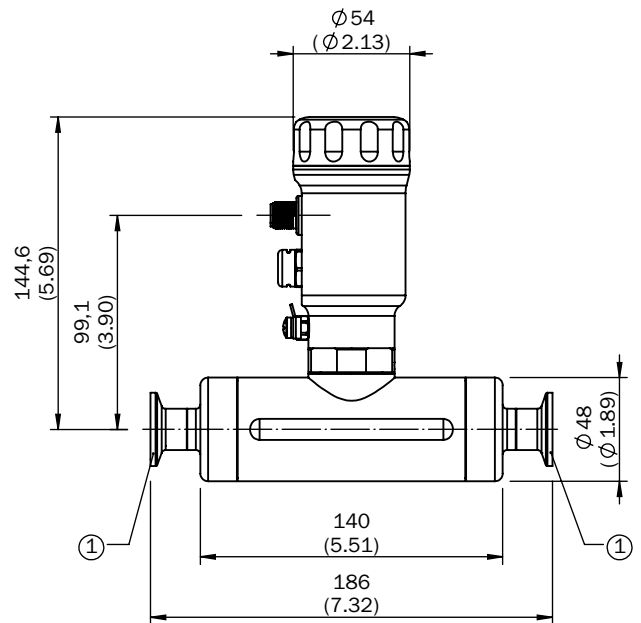

Clamp (DIN 32676) DN 25

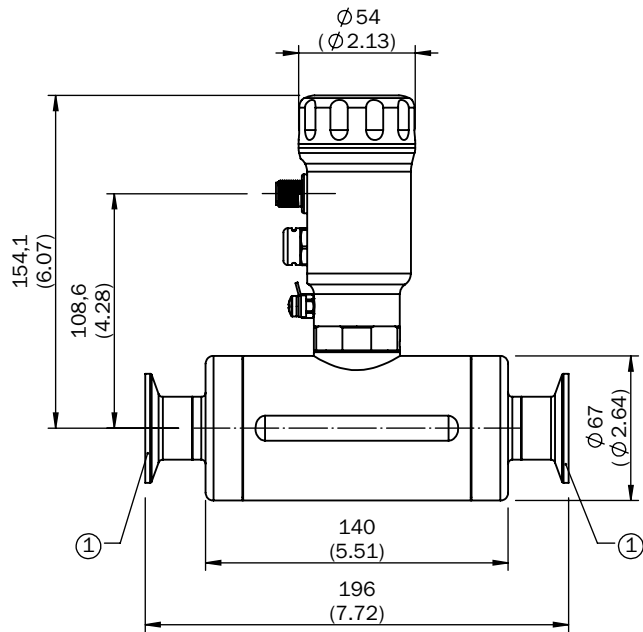

DN 25, G 1 1/4

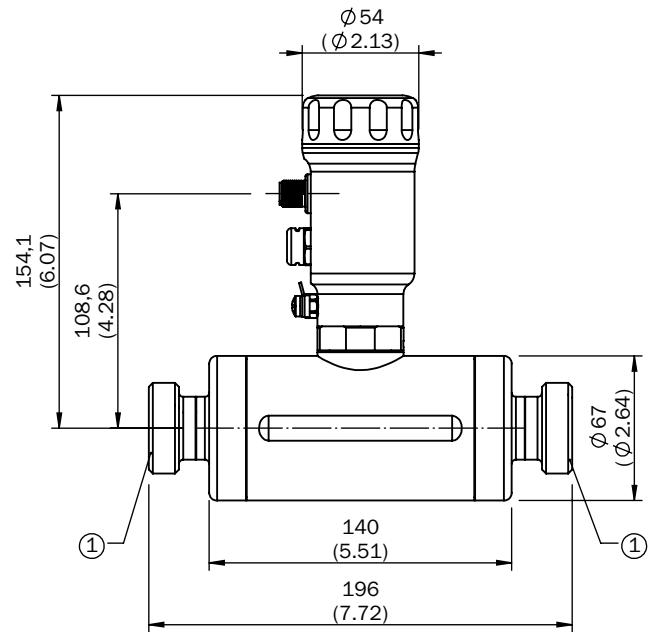

DIN 11851 DN 25

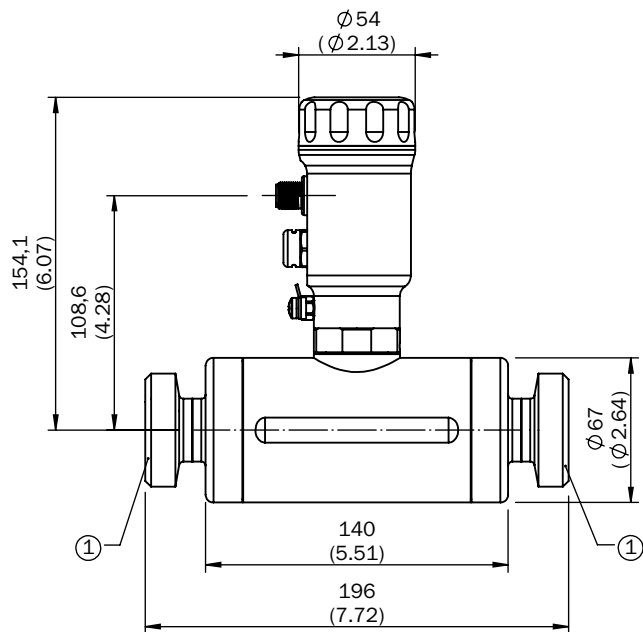

DN 25, 1 1/4" NPT

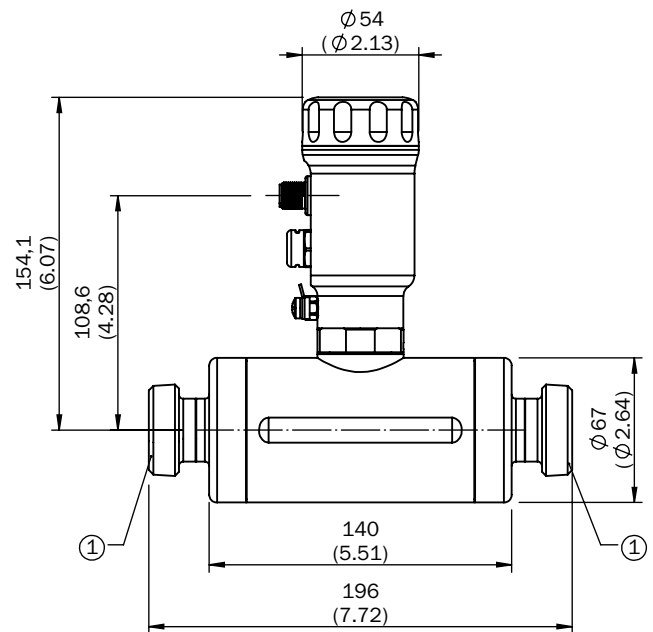

Recommended accessories

Connection systems









Modules and gateways







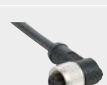





Connection modules

	Brief description	Type	Part no.
	IO-Link V1.1 Class A port, USB2.0 port, optional external power supply 24V / 1A	IOLA2US-01101 (SiLink2 Master)	1061790

Plug connectors and cables

Connecting cables with female connector

	Brief description	Cable length	Type	Part no.
 Illustration may differ	Head A: female connector, M12, 5-pin, straight Head B: cable Cable: PVC, unshielded, Ø 5.7 mm	2 m	DOL-1205-G02M	6008899
	Head A: female connector, M12, 5-pin, straight Head B: cable Cable: Power, I/O, drag chain use, PUR, halogen-free, unshielded, Ø 5 mm	2 m	DOL-1205-G02MC	6025906
 Illustration may differ	Head A: female connector, M12, 5-pin, straight Head B: cable Cable: PVC, unshielded, Ø 5.7 mm	5 m	DOL-1205-G05M	6009868
	Head A: female connector, M12, 5-pin, straight Head B: cable Cable: drag chain use, PUR, halogen-free, unshielded, Ø 5 mm	5 m	DOL-1205-G05MC	6025907
 Illustration may differ	Head A: female connector, M12, 5-pin, straight Head B: cable Cable: PVC, unshielded, Ø 5.7 mm	10 m	DOL-1205-G10M	6010544
	Head A: female connector, M12, 5-pin, straight Head B: cable Cable: drag chain use, PUR, halogen-free, unshielded, Ø 5 mm	10 m	DOL-1205-G10MC	6025908
 Illustration may differ	Head A: female connector, M12, 5-pin, angled Head B: cable Cable: PVC, unshielded, Ø 5.7 mm	2 m	DOL-1205-W02M	6008900
	Head A: female connector, M12, 5-pin, angled Head B: cable Cable: Power, I/O, drag chain use, PUR, halogen-free, unshielded, Ø 5 mm	2 m	DOL-1205-W02MC	6025909
 Illustration may differ	Head A: female connector, M12, 5-pin, angled Head B: cable Cable: PVC, unshielded, Ø 5.7 mm	5 m	DOL-1205-W05M	6009869
	Head A: female connector, M12, 5-pin, angled Head B: cable Cable: drag chain use, PUR, halogen-free, unshielded, Ø 5 mm	5 m	DOL-1205-W05MC	6025910

	Brief description	Cable length	Type	Part no.
 Illustration may differ	Head A: female connector, M12, 5-pin, angled Head B: cable Cable: PVC, unshielded, Ø 5.7 mm	10 m	DOL-1205-W10M	6010542
	Head A: female connector, M12, 5-pin, angled Head B: cable Cable: drag chain use, PUR, halogen-free, unshielded, Ø 5 mm	10 m	DOL-1205-W10MC	6025911
	Head A: female connector, M12, 8-pin, straight Head B: cable Cable: PVC, shielded, Ø 7.7 mm	2 m	DOL-1208-G02MA	6020633
	Head A: female connector, M12, 8-pin, straight Head B: cable Cable: drag chain use, PUR, halogen-free, unshielded, Ø 5.9 mm	2 m	DOL-1208-G02MC	6035620
	Head A: female connector, M12, 8-pin, straight Head B: cable Cable: PVC, shielded, Ø 7.7 mm	5 m	DOL-1208-G05MA	6020993
	Head A: female connector, M12, 8-pin, straight Head B: cable Cable: drag chain use, PUR, halogen-free, unshielded, Ø 5.9 mm	5 m	DOL-1208-G05MC	6035621
	Head A: female connector, M12, 8-pin, straight Head B: cable Cable: PVC, shielded, 7.7 mm	10 m	DOL-1208-G10MA	6022152
	Head A: female connector, M12, 8-pin, straight Head B: cable Cable: drag chain use, PUR, halogen-free, unshielded, Ø 5.9 mm	10 m	DOL-1208-G10MC	6035622
	Head A: female connector, M12, 8-pin, angled Head B: cable Cable: PVC, shielded, Ø 7.7 mm	2 m	DOL-1208-W02MA	6020992
	Head A: female connector, M12, 8-pin, angled Head B: cable Cable: PUR, unshielded	2 m	DOL-1208-W02MC	6035623
	Head A: female connector, M12, 8-pin, angled Head B: cable Cable: PVC, shielded, Ø 7.7 mm	5 m	DOL-1208-W05MA	6021033
	Head A: female connector, M12, 8-pin, angled Head B: cable Cable: PUR, unshielded	5 m	DOL-1208-W05MC	6035624
		10 m	DOL-1208-W10MC	6035625

DOL-1205-G02M  
DOL-1205-G05M  
DOL-1205-G10M

DOL-1205-G02MC  
DOL-1205-G05MC  
DOL-1205-G10MC

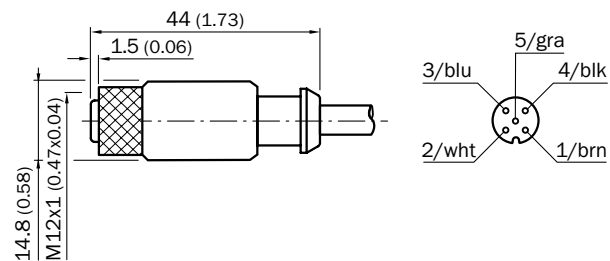
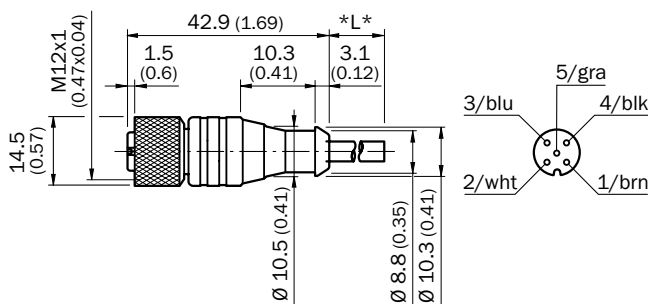

DOL-1205-W02M  
 DOL-1205-W05M  
 DOL-1205-W10M

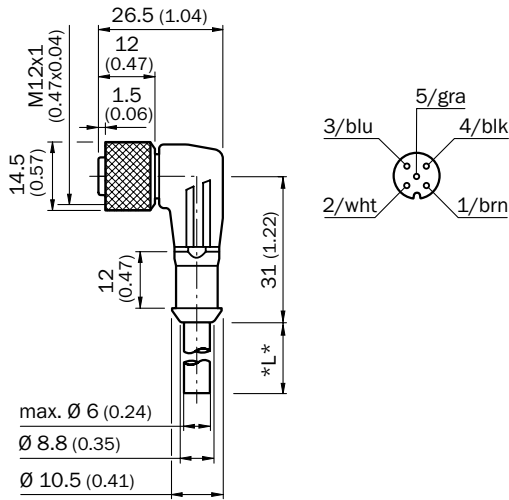

DOL-1205-W02MC  
 DOL-1205-W05MC  
 DOL-1205-W10MC

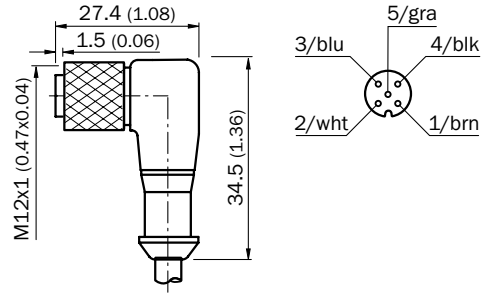

DOL-1208-G02MA  
 DOL-1208-G05MA  
 DOL-1208-G10MA

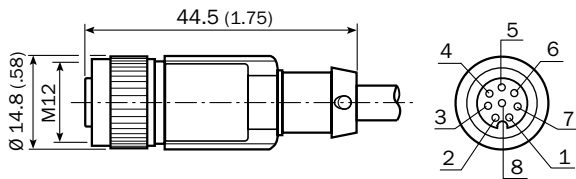

DOL-1208-G02MC  
 DOL-1208-G05MC  
 DOL-1208-G10MC

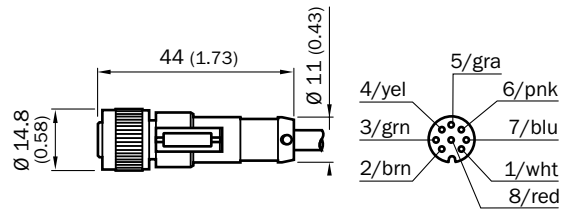

DOL-1208-W02MA  
 DOL-1208-W02MC  
 DOL-1208-W05MC  
 DOL-1208-W10MC

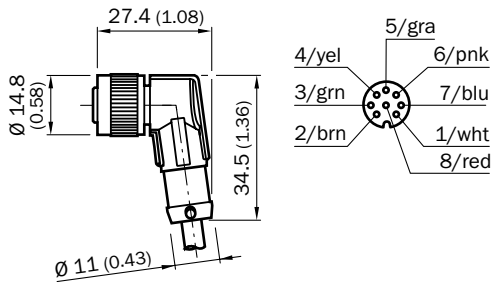

DOL-1208-W05MA

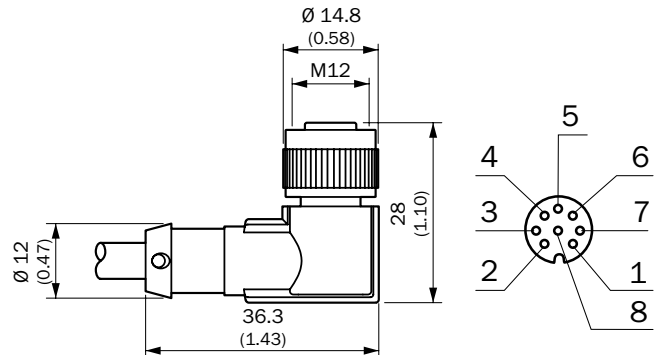

female connector M 12 x 1, angled, screened

Further accessories

Spare parts

Brief description	Type	Part no.
Cover closed, material 1.4305	Cover closed	2067269

## REGISTER AT WWW.SICK.COM TODAY AND ENJOY ALL THE BENEFITS



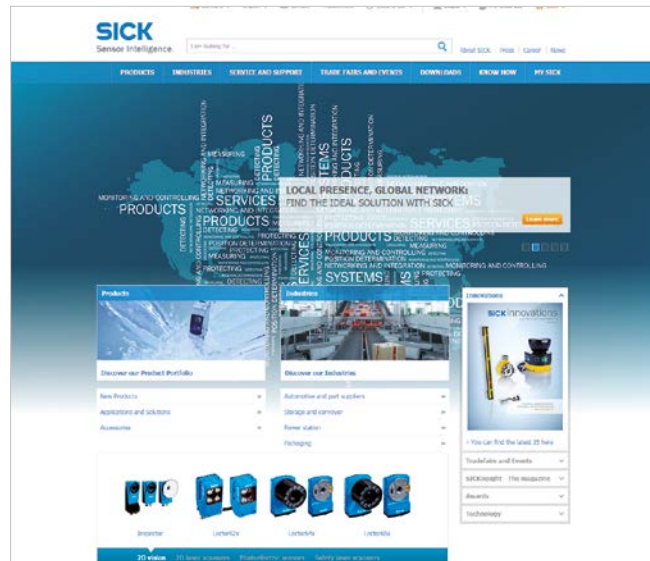

- ✔ Select products, accessories, documentation and software quickly and easily.
- ✔ Create, save and share personalized wish lists.
- ✔ View the net price and date of delivery for every product.
- ✔ Requests for quotation, ordering and delivery tracking made easy.
- ✔ Overview of all quotations and orders.
- ✔ Direct ordering: submit even very complex orders in moments.
- ✔ View the status of quotations and orders at any time. Receive e-mail notifications of status changes.
- ✔ Easily repeat previous orders.
- ✔ Conveniently export quotations and orders to work with your systems.



## SERVICES FOR MACHINES AND SYSTEMS: SICK LifeTime Services

Our comprehensive and versatile LifeTime Services are the perfect addition to the comprehensive range of products from SICK. The services range from product-independent consulting to traditional product services.



- 
**Consulting and design**  
 Safe and professional
- 
**Product and system support**  
 Reliable, fast and on-site
- 
**Verification and optimization**  
 Safe and regularly inspected
- 
**Upgrade and retrofits**  
 Easy, safe and economical
- 
**Training and education**  
 Practical, focused and professional

## SICK AT A GLANCE

SICK is a leading manufacturer of intelligent sensors and sensor solutions for industrial applications. With more than 7,400 employees and over 50 subsidiaries and equity investments as well as numerous agencies worldwide, we are always close to our customers. A unique range of products and services creates the perfect basis for controlling processes securely and efficiently, protecting individuals from accidents and preventing damage to the environment.

We have extensive experience in various industries and understand their processes and requirements. With intelligent sensors, we can deliver exactly what our customers need. In application centers in Europe, Asia and North America, system solutions are tested and optimized in accordance with customer specifications. All this makes us a reliable supplier and development partner.

Comprehensive services round out our offering: SICK LifeTime Services provide support throughout the machine life cycle and ensure safety and productivity.

**For us, that is “Sensor Intelligence.”**

### **Worldwide presence:**

Australia, Austria, Belgium, Brazil, Canada, Chile, China, Czech Republic, Denmark, Finland, France, Germany, Great Britain, Hungary, India, Israel, Italy, Japan, Malaysia, Mexico, Netherlands, New Zealand, Norway, Poland, Romania, Russia, Singapore, Slovakia, Slovenia, South Africa, South Korea, Spain, Sweden, Switzerland, Taiwan, Thailand, Turkey, United Arab Emirates, USA, Vietnam.

Detailed addresses and further locations → [www.sick.com](http://www.sick.com)